



INTERNATIONAL APPLICATION PUBLISHED UNDER THE PATENT COOPERATION TREATY (PCT)

<p>(51) International Patent Classification ⁶ : A61B 17/58</p>	<p>A1</p>	<p>(11) International Publication Number: WO 98/32384 (43) International Publication Date: 30 July 1998 (30.07.98)</p>
<p>(21) International Application Number: PCT/US98/01655 (22) International Filing Date: 27 January 1998 (27.01.98) (30) Priority Data: 60/036,220 28 January 1997 (28.01.97) US (71) Applicant (for all designated States except US): NEW YORK SOCIETY FOR THE RUPTURED AND CRIPPLED MAINTAINING THE HOSPITAL FOR SPECIAL SURGERY [US/US]; 535 East 70th Street, New York, NY 10021 (US). (72) Inventors; and (75) Inventors/Applicants (for US only): ROBIE, Bruce [US/US]; Apartment 9F, 1161 York Avenue, New York, NY 10021 (US). RYALLS, Jordan [US/US]; Apartment 10, 736 Broadway, New York, NY 10003 (US). LIPMAN, Joseph [US/US]; Apartment 4B, 531 East 72nd Street, New York, NY 10021 (US). BURSTEIN, Albert, H. [US/US]; Apartment 552, 2110 Harbourside Drive, Longboat Key, FL 34228 (US). (74) Agents: SWEEDLER, Michael, J. et al.; Darby & Darby P.C., 805 Third Avenue, New York, NY 10022 (US).</p>		<p>(81) Designated States: AU, CA, JP, KR, US, European patent (AT, BE, CH, DE, DK, ES, FI, FR, GB, GR, IE, IT, LU, MC, NL, PT, SE). Published <i>With international search report. Before the expiration of the time limit for amending the claims and to be republished in the event of the receipt of amendments.</i></p>

(54) Title: METHOD AND APPARATUS FOR FEMORAL RESECTION

(57) Abstract

An instrument is provided for use in shaping a femur preparatory to implantation of a knee prosthesis. A gap checking device (40) is fixed to the distal end of the patient's femur and referenced to the epicondyles of the femur. The gap checking device (40) includes slots (70, 72, 74, 76, 78) through which a cutting instrument can be passed to shape the femur so that it can receive the femoral component of the prosthesis. One of the slots (70) enables the distal femoral cut to be made. The thickness of the gap setting device (40) is selected so that the distance between the distal femoral cut and the distal surface of the gap setting device plus the thickness of a shim resting on the cut proximal tibial surface is equal to the combined thickness of the tibial and femoral components of the prosthesis. This enables the flexion and extension gaps to be checked before the femoral cuts are made. The epicondyles can be located using intramedullary or extramedullary referencing. A special extramedullary locating device (10) is also described which is referenced to the trochlear groove of the femur and enables the placement of pins (38) in the epicondyles so that the gap checking device (40) can be properly situated with respect to the femur.

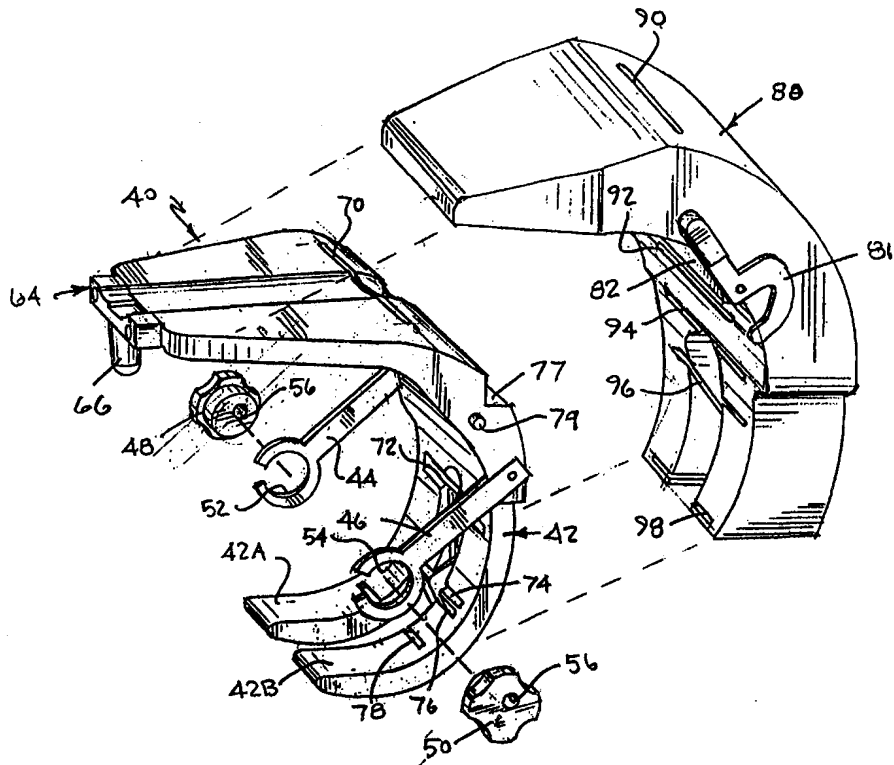

FOR THE PURPOSES OF INFORMATION ONLY

Codes used to identify States party to the PCT on the front pages of pamphlets publishing international applications under the PCT.

AL	Albania	ES	Spain	LS	Lesotho	SI	Slovenia
AM	Armenia	FI	Finland	LT	Lithuania	SK	Slovakia
AT	Austria	FR	France	LU	Luxembourg	SN	Senegal
AU	Australia	GA	Gabon	LV	Latvia	SZ	Swaziland
AZ	Azerbaijan	GB	United Kingdom	MC	Monaco	TD	Chad
BA	Bosnia and Herzegovina	GE	Georgia	MD	Republic of Moldova	TG	Togo
BB	Barbados	GH	Ghana	MG	Madagascar	TJ	Tajikistan
BE	Belgium	GN	Guinea	MK	The former Yugoslav Republic of Macedonia	TM	Turkmenistan
BF	Burkina Faso	GR	Greece			TR	Turkey
BG	Bulgaria	HU	Hungary	ML	Mali	TT	Trinidad and Tobago
BJ	Benin	IE	Ireland	MN	Mongolia	UA	Ukraine
BR	Brazil	IL	Israel	MR	Mauritania	UG	Uganda
BY	Belarus	IS	Iceland	MW	Malawi	US	United States of America
CA	Canada	IT	Italy	MX	Mexico	UZ	Uzbekistan
CF	Central African Republic	JP	Japan	NE	Niger	VN	Viet Nam
CG	Congo	KE	Kenya	NL	Netherlands	YU	Yugoslavia
CH	Switzerland	KG	Kyrgyzstan	NO	Norway	ZW	Zimbabwe
CI	Côte d'Ivoire	KP	Democratic People's Republic of Korea	NZ	New Zealand		
CM	Cameroon		Republic of Korea	PL	Poland		
CN	China	KR	Republic of Korea	PT	Portugal		
CU	Cuba	KZ	Kazakstan	RO	Romania		
CZ	Czech Republic	LC	Saint Lucia	RU	Russian Federation		
DE	Germany	LI	Liechtenstein	SD	Sudan		
DK	Denmark	LK	Sri Lanka	SE	Sweden		
EE	Estonia	LR	Liberia	SG	Singapore		

5

10

**METHOD AND APPARATUS FOR
FEMORAL RESECTION**

15 Field of the Invention

This invention relates to an instrument and method for shaping a femur preparatory to implanting a knee prosthesis.

Background of the Invention

20 A total knee replacement or prosthesis, substitutes for a patient's arthritic or otherwise dysfunctional natural knee joint. The prosthesis offers the patient an alternative treatment for the chronic pain and discomfort often associated with such problems.

25 Burstein et al. U.S. patent No. 4,298,992 illustrates a popular total knee joint prosthesis known as the Insall-Burstein (I/B) knee. Such prostheses comprise a femoral component which is attached to the patient's femur a tibial component attached to the patient's tibia and a patellar
30 component attached to the patient's patella. To use this prosthesis, it is necessary to shape by resection the patient's femur, tibia and patellar. The tibia and patellar are shaped by a flat cut. In the case of the I/B prosthesis, the femoral component requires five cuts in the distal end of the femur.
35 These cuts conform to complementary portions of the femoral component which engage the bone. It is important that these femoral cuts be made precisely and located so that the position

of the femoral component and the tibial component will closely approximate the positions of their anatomical counterparts. Proper positioning of the femoral and tibial components is required to insure the patient's natural anatomic limb alignment and normal anatomical movement.

As part of the installation of a knee joint prosthesis, it is important to balance the ligaments crossing the joint. Balancing the ligaments means performing soft tissue releases, as necessary, so as to ensure that when the femur is lifted off of the tibia by a force directed along the long axis of the tibia, there is translation but no rotation of the femur with respect to the tibia, and that the amount of translation is nearly the same when the knee is fully extended (extension) and when it is bent at ninety degrees (flexion). The amount of translation is commonly called the gap and the process of lifting the femur and evaluating the translation and rotation is referred to as checking the gaps. Heretofore, gap checking has been done after the femur has been shaped. If proper balancing can not be achieved, then it may be necessary to reshape the femur which is obviously undesirable, or to use a more constrained total knee design, thus limiting knee motion.

An object of the invention is to provide an instrument for use in shaping the distal surface of a femur preparatory to implantation of a knee prosthesis in which the gaps can be checked and adjusted prior to shaping the femur. This eliminates the need to recut the femur and reduces the time required for surgery. Moreover, since it is easier to check the gaps with the invention, it is likely that more surgeons will take the time to check the gaps and, therefore, the quality of the surgery will improve.

A further object of the invention is to provide a device for shaping the distal surface of a femur preparatory to implanting a knee prosthesis wherein all of the cuts required to shape the femur can be made using a single instrument.

The most popular types of instruments used to shape the femur are intramedullary devices in which a cutting guide is positioned at the distal end of the femur relative to a rod which is driven into the intramedullary canal of the femur. Historically, surgeons have also used extramedullary alignment to orient the instruments to cut the distal femur. The present invention includes the capability of working with either intramedullary or extramedullary alignment. In the extramedullary alignment version, the invention references the trochlear groove (sulcus) of the distal femur and the medial epicondyle thereby locating the cutting instrument relative to established soft tissue landmarks to ensure that the knee prosthesis works in concert with the ligaments of the knee.

The present invention also provides an instrument for administering the femoral bone cuts required in total knee replacement surgery by referencing the femoral epicondyles which provide established soft tissue landmarks to ensure that the knee prosthesis works in concert with the ligaments of the knee.

20 Summary of the Invention

The principal component of the knee instrument according to the invention comprises a gap checking device which includes a curved base adapted to engage the distal end of the patient's femur. The gap checking device includes various slots for guiding the cutting instrument used to shape the femur. Included are slots through which the distal cut of the femur can be made. The gap checking device can be referenced to the patient's femur by means of an intramedullary rod or by means of a special extramedullary locator device.

The thickness of the gap checking device is such that the distance between the distal cut in the femur and the distal surface of the gap checking device corresponds in a predetermined way to the thickness of the femoral and tibial components of the prosthesis. Accordingly, extension and flexion gaps can be checked using a thin shim on the cut surface of the tibia to

prevent bone damage. After the knee has been properly balanced, a cutting guide is attached to the gap checking device. The cutting guide and gap checking device include slots through which the bone cuts can be made.

5 In accordance with a further feature of the invention, an extramedullary locator device may be used to locate the epicondyles of the femur. Once the epicondyles have been properly located, they may be used as reference points to properly position the gap checking device.

10

The Drawings

Fig. 1 is a perspective view of the locating/sizing device;

15 Fig. 2 is a front plan view showing the locating/sizing device applied to the distal end of a femur;

Fig. 3 is a top plan view of the locating/sizing device applied to a femur;

Fig. 4 is a side sectional view showing how the locating/sizing device is used to locate the epicondyles;

20 Fig. 5 is a sectional view through the line 5-5 of Fig. 4;

Fig. 6 is an exploded perspective view showing the gap checking device and cutting device;

25 Fig. 7a is a side plan view a bushing which can be used with the gap checking device shown in Fig. 6;

Fig. 7b is a side plan view of another form of bushing which can be used with the gap checking device of Fig. 6;

Fig. 8 is a side plan view showing the gap checking device and cutting guide attached to the epicondyles of a femur;

30 Fig. 9 is a top plan view of the cutting device and gap checking device shown in Fig. 8; and

Fig. 10 is a sectional view along the line 10-10 of Fig. 9.

35 Fig. 11 is perspective view of a locating device according to a second embodiment of the invention;

Fig. 12 is a sectional view along the line 12-12 of Fig. 11;

Fig. 13 is a front view partially in section of the locating device shown in Fig. 11;

5 Fig. 14 is an exploded perspective view showing the gap checking device and cutting guide according to a second embodiment of the invention;

Fig. 15 shows one of the outrigger arms of the gap checking device viewed from inside the device;

10 Fig. 15A is a view of an outrigger arm viewed from inside of the device with a hole plate inserted in the arm;

Fig. 16 is a sectional view along the line 16-16 of Fig. 15A;

15 Fig. 17 is an exploded perspective view of a gap checking device of the type shown in Figs. 14-16, modified for use with an intramedullary rod;

Fig. 18 is a perspective view from the front showing the assembled gap checking device and intramedullary attachment means of Fig. 17;

20 Fig. 19 is a side plan view of the assembled gap checking device and intramedullary attachment means shown in Figs. 17 and 18; and

Fig. 20 is a side plan view, partially in section, showing the assembled gap checking device and cutting guide.

25

Detailed Description

The instrumentation according to the invention consists of three parts - a locating/sizing device, a gap checking device, and a cutting guide. The locator/sizing device is used to locate
30 the epicondyles and to provide an indication of the appropriate size of the knee prosthesis. The gap checking part is the device which enables the surgeon to balance the patient's knee in flexion and extension before any of the femoral cuts are made. The cutting guide attaches to the gap checking device and, in

combination with the gap checking device, guides a cutting blade so that the necessary femoral cuts can be made.

The locator/sizing instrument 10 is illustrated in Figs. 1-5. It comprises clamp formed by an L-shaped upper arm 12 having vertical and horizontal sections 12V and 12H, and an L-shaped lower arm 14 having vertical and horizontal sections 14V and 14H. The horizontal section 12H and 14H are dovetailed together (Fig. 4) so that they can slide with respect to each other to form an adjustment mechanism and define an epicondyle locating portion. Epicondylar locator cups 16 and 18 are rotatably mounted in an inwardly confronting orientation to the lower extremities of the arms 12V and 14V, respectively. The horizontal sections 12H and 14H of the upper and lower arms include elongated slots 20 and 22, respectively (Fig. 3).

An elongated pin or stylus 24 extends vertically through slots 20 and 22 and through a hole 28 in a stylus mount 30 which is shaped so that it dovetails with the underneath portion of the horizontal section 14H of the lower arm 14. (See Fig. 4.) The stylus slides freely within the stylus mount 30 and can be moved with the stylus mount within the elongated slots 20 and 22, i.e. left and right as viewed in Fig. 3. The relative position of the upper and lower arms 12 and 14 can be fixed by means of a set screw 32 which is threadedly received in a plate 34 fastened to the forward surface (as viewed in Fig. 1) of the horizontal portion 12H of the upper arm.

For ease of explanation, terms such as horizontal, vertical, upper, lower, etc. are used with reference to the drawings. These terms are not intended to apply to the actual orientation of the parts during use.

The shapes of the epicondylar locator caps 16 and 18 are identical. As shown in Fig. 5, each includes a stem 35 which rotates within the lower extremity of the arm section 12V or 14V. An axial bore 36 extends through the stem 35 so that a pin 38 can be driven into the patient's epicondyle after the device 10 has been properly located.

The locating/sizing device of Figs. 1-5 is used as follows. The knee prosthesis will be available in a number of different sizes, for example, six. There will be a set of instruments corresponding to each size, but one locating/sizing device for all sizes. The patient's knee joint is exposed in the usual fashion and the tibial surface cut. With the knee in flexion, the locating/sizing device 10 is positioned on the knee with the locator cup 16 and 18 placed as close as possible to the patient's epicondyles. The set screw 32 is then tightened to secure the arms 12 and 14 relative to each other, with the cups 16 and 18 firmly grasping the knee. (Sizing can also be indicated by where arms 12 and 14 are located relative to one another.)

The arms 12 and 14 are rotated with respect to the cups 16 and 18 to the solid line position shown in Fig. 4, that is, with the device generally perpendicular to the axis of the patient's femur. The stylus mount 30 is then positioned so that the stylus 24 drops into the bottom of the trochlear groove of the femur (i.e. in and out of the plane of the paper in Fig. 3). The position of the stylus 24 when it contacts the bottom of the trochlear groove provides an indication of the size of the prosthesis that will be required. Thus, by including appropriate markings on the stylus, the surgeon is provided with an indication of the size of the desired prosthesis.

In order to make sure that the epicondyles have been properly located, the device 10 is then rotated to the dashed line position shown in Fig. 4. If the stylus 24 rides in the bottom of the trochlear groove throughout this arc of motion, the epicondyles have been properly located. If not, the set screw 32 must be loosened and the position of the device adjusted until the stylus rides in the bottom of the groove.

When the epicondyles are properly located, pins 38 are driven through the axial bores 36 directly into the patient's epicondyles. Set screw 32 is then loosened, the arms 12 and 14

separated, and the device 10 removed, leaving the two pins 38 in place in the epicondyles.

The second part of the instrumentation is the gap checking device which is shown at 40 (Figs. 6, 8, 9 and 10).

5 The gap checking device 40 comprises a curved base 42 having two bifurcated portions 42A and 42B which overlay the femoral condyles. An elongated apparatus comprising a pair of outrigger arms 44 and 46 is immovably attached to opposite sides of the base 42. Bushings 48 and 50 are positioned within
10 suitably shaped apertures 52 and 54, respectively, in the free ends of the outrigger arms 44 and 46. The bushings 48 and 50 each include a retention hole 56, and are shaped so that they can be readily rotated by hand.

A stylus 64 having a ball tip 66 is attached to the end
15 of the curved base 42 which overlies the femur during the operation. An axial bore 68 (Fig. 10) extends through the ball tip 66 so that when the gap checking device is properly positioned it can be pinned to the femur.

As shown most clearly in Fig. 10, the gap checking
20 device 40 includes slots 70, 72, 74, 76 and 78 which, as explained below, guide the blades used to shape the surface of the femur to receive the femoral component of the prosthesis.

With the pins 38 (Fig. 9) in place in the epicondyles, the gap checking device is mounted on the femur with the pins 38
25 passing through the apertures 52 and 54 in the outrigger arms 44 and 46. The bushings 48 and 50 are then placed in the apertures 52 and 54 so that the pins 38 are inserted into the holes 56 in the bushings. To secure the gap checking device to the femur, the device is rotated until the stylus ball tip 66 contacts the
30 femur at which point a pin (not shown) is driven through the axial bore 68 of the stylus into the femur.

Once the gap checking device 40 is secured in its proper position, it can be used to check the balance of the ligaments in extension, flexion and any position in between. If
35 the ligaments are not balanced, the surgeon may perform selected

releases of soft tissue (ligaments, capsule, muscle) to balance the gaps in the conventional manner, while the gap checking device is still attached to the femur.

5 The thickness dimensions of the curved base 42 (i.e. as viewed in Fig. 10, for example) are important. In order to properly balance the ligaments, the thickness of the curved base 42 should be such that when it is placed on a thin shim used to protect the cut surface of the tibia, the patient's femur and tibia will be separated by the same distance that they will be
10 separated after the entire knee prosthesis is in place. In other words, the thickness of the shim plus the distance from the distal surface of the gap checking device to the distal cut surface in the femur (formed by the cutting blade inserted through slots 70 and 90), represented by the distance D in Figure
15 10, must be equal to the thickness of the femoral knee component (measured from the surface mating with the aforesaid distal cut surface of the femur to the distal extremity of the femoral component) plus the thickness of the tibial insert plus the thickness of the tibial tray. To accommodate different
20 thicknesses of tibial inserts, matching shims of different thicknesses are provided.

A feature of the invention is the use of the bushings 48 and 50 which permit slight changes in orientation of the device if the holes 56 are off-center. Fig. 7A shows an
25 arrangement in which the hole 56 is in the center of the bushing in which case no adjustment is possible. In Fig. 7B, however, the hole 56 is off-center so that if the bushing is rotated within the openings of the outrigger arms 44 or 46 the position of the gap checking device can be changed slightly. For example,
30 this feature may be used when it becomes necessary to shift the position of the femoral component proximally, perhaps due to a flexion contracture. By placing the offset bushings on the pins 38, and rotating the bushings 48 and 50 until the holes are oriented more distally, the gap checking device 40 is shifted
35 proximally.

After all of the gaps have been checked and the ligaments balanced, a cutting guide 80 is secured to the gap checking device 40. The cutting guide 80 includes two fixation hooks 81 which engage posts 79 on the sides of the gap checking device 40. In addition, the cutting guide 80 includes an interior projection 82 (Fig. 10) which engages a complementary shaped recess 77 in the outer surface of the gap checking device 40 to ensure proper positioning of the cutting guide relative to the gap checking device. As shown in Fig. 10, the cutting guide includes slots 90, 92, 94, 96 and 98 which align with the corresponding slots 70, 72, 74, 76 and 78 of the gap checking device, forming slots through which a cutting blade can be inserted to shape the femur. The distal cut is made through slots 70 and 90. Next, the posterior cut is made through slots 78 and 98, and the anterior cut through slots 72 and 92. The anterior chamfer cut is made through slots 76 and 96, and the posterior chamfer cut is made through slots 74 and 94.

Figures 11 - 19 illustrate a second embodiment of the invention. The principal difference between the two embodiments resides in the construction of the locating device. Moreover, as explained below, a further modification is provided so that an intramedullary rod can be used to position the gap checking device.

Instead of two L-shaped arms, the locating device in the modified embodiment comprises a cross-bar 102 having parallel arms 102A and 102B connected by a transverse cross-piece 102C. An adjustable tubular locator 104 is threadably received in a bore (not numbered) in the free extremity of the arm 102A. A somewhat shorter, fixed tubular locator 106 is fixed in the free end of arm 102B. Epicondylar pins 108 and 110, respectively, extend from and are slidably received within the locators 104 and 106, respectively. The outer ends of the locators 104 and 106 have fastened thereto tamp stops 112 and 114 through which pin tamps 116 and 118, respectively, slidably extend. The pin tamps 116 and 118 can be tamped by the surgeon to apply pressure to the

pins 108 and 110 and drive them into the patient's epicondyles after the locator has been properly positioned.

As shown in Figure 13, the forward portions of the pin tamps 116 and 118 are tubular. The back ends of the pins 108 and 110 are positioned in these tubular forward portions which abut against collars 108A and 110A on pins 108 and 110. Pressure applied to the exposed ends of the tamps 116 and 118 will therefore drive the pins 108 and 110 into the patient's epicondyles when the pins are properly positioned.

The pin tamps 116 and 118 also include collars 116A and 118A which move in slightly enlarged bores 104A and 106A in the tubular locators 104 and 106. This arrangement prevents withdrawal of the tamps (due to abutment of the collars 116A and 118A against stops 112 and 114) and limits the forward movement of the tamps (by abutment of the collars 116A and 118A against the forward edges of the enlarged bores 104A and 106A).

The stylus used in the locator shown in Figures 11 - 13 differs considerably from the stylus used in the locator shown in Figures 1 - 4. The stylus, indicated generally at 120, comprises, a posterior jaw 122 which includes an inwardly bent finger 123 and a yoke like section 124 to which a link 126 and anterior jaw 128 are pivotally attached. A pin 129, retained in yoke 124, rides in an elongated slot 127 in the link 126. This enables the link to be adjusted in an anterior-posterior and proximal-distal directions during use of the locator. The anterior jaw 128 pivots on a pin 131 which extends through link 126 and the bifurcated end (not numbered) of jaw 128.

The posterior jaw 122 also includes a stem 123 which extends upwardly through a rectangular slot 130 in cross-piece 102C and engages a movable stylus guide 132. The stylus guide 132 has outwardly extending rails 133 which slide within complementary tracks 135 in the upper surface of the cross-piece 102C.

The purpose of the locating device shown in Figures 11-13 is to locate the plane which passes through the bottom of the

trochlear groove and is perpendicular to the epicondyle axis (an imaginary line which passes between the medial and lateral epicondyles). This is done by positioning the instrument with the inner ends of the locators 104 and 106 in the vicinity of the epicondyles. Stylus 120 is then dropped until the finger 123 of posterior jaw 122 engages the protruding ridge near the distal end of the femur. The anterior jaw 128 is then rotated toward the femur and the curved surface is pressed into the bottom of the trochler groove. If it engages the bottom of the trochlear groove, the jaws 122 and 128 will define the plane which is sought, i.e., a plane passing through the bottom of the trochlear groove and perpendicular to the epicondyle axis. The entire instrument itself can be moved slightly and the stylus 120 positioned along the medial-lateral axis until the adjustable locator 104 can be advanced to set the pins 108 and 110 within the epicondyles.

The gap checking device and cutting guide shown in Figures 14 - 19 are very much like the gap checking device and cutting guide of Figures 6 - 10. Changes have been made in both devices to reduce the bulk which not only makes the devices easier to handle but also offers less obstruction to the surgeon's view of the surgical site. To the extent the components of the gap checking device and cutting guide correspond to previously described components of Figures 1 - 10, those components are identified by the same numerals followed by a prime symbol (').

One of the differences in the gap checking device is the provision of two plates 140 which are used in combination with the bushing caps 48' and 50'. The outrigger arms 44' and 46' are secured to the main section of the gap checking device 42' by screws 139. The outrigger arms are identical. Arm 46' terminates in a circular collar which includes an end wall 137 having an opening through which the pins extend and a recess (not numbered) which conforms in shape to the portion of the hole plate 140 which contains the holes 142 and 144 so that each hole

plate can be securely seated in one of the outrigger arms. Each plate includes a narrow waist 141 which fits within a slot 143 in the associated arm so that a plate 140 can be inserted into an outrigger aperture 52' or 54'.

5 The plates 140 each include a neutral hole 142 and an offset hole 144 through which the pins 108 and 110 can be extended (Figs. 15A and 16). Moreover, the holes 142 and 144 may be asymmetrical with respect to the longitudinal axis 145 (Fig. 15A) of the plate 140. As a result, each plate 140 can be
10 rotated 180° about its longitudinal axis to provide for posterior/anterior adjustment of the gap checking device 40'. Thus, in this embodiment, adjustment is possible along the axis of the femur (by selecting hole 142 or 144) and along the anterior/posterior axis.

15 The gap checking device in this embodiment may include further slots 76'' which cooperate with the slots 76' to assist in making the anterior chamfer cut.

 The cutting guide 80' has much less bulk than cutting guide 80 but is functionally the same. To retain the gap
20 checking device 40' and cutting guide 80' together during the shaping operation, a thumb screw 150 is inserted through a hole 152 within the cutting guide 80' and into engagement with a threaded bore 154 on the gap checking device 40'.

 The operation of the instrument shown in Figures 11 -
25 16 is as follows.

 The adjustable locator 104 is moved so that the distance between the opposing ends of the pins 108 and 110 approximates the distance between the patient's medial and lateral epicondyles. As a general rule, it is easier for the
30 physician to locate the medial epicondyle; therefore, with the pin 108 adjacent the medial epicondyle, the stylus 120 is dropped as described above. After the locator is positioned with jaws 122 and 128 defining the plane passing through the bottom of the trochlear groove, the medial locator 104 is advanced causing pins
35 108 and 110 to engage the medial and lateral epicondyles,

respectively. The physician then tamps the pins 108 and 110 into the epicondyles. With both of the pins located, the adjustable locator 104 is withdrawn by unscrewing it, using the wings on the adjustable tamp stop 112. After the pin 108 has been cleared,
5 the locator can be removed from the patient's knee.

With the pins 108 and 110 extending into the epicondyles, the gap checking device 42' is placed roughly into position with the pins passing through the slots 143 in the collars of the outrigger arms. The hole plates 140 with the
10 desired posterior/anterior orientation are then inserted into the outrigger collars 52' and 54' with the pins passing through either the holes 142 or 144. The hole plates 140 are nested in the recesses within the wall 137 and the bushings 48' and 50' inserted into the collars as shown in Fig. 16. With the plates
15 140 properly seated within the end walls 137 of the outrigger arms 44' and 46', respectively, the gap checking device 42' is positioned as described above with respect to Figures 1-10. The application and use of the gap checking device to check the extension and flexion gaps, the balancing of the soft tissues (if
20 necessary), and the cutting of the femur is the same as described above with respect to the embodiment of Figures 1-10. In both cases, the device can be used to check the gaps at angles between 90° (flexion) and 180° (extension).

As indicated above, it is also contemplated that the
25 gap checking device and cutting guide can be used in an intramedullary procedure, i.e. in procedure in which an intramedullary rod is inserted into the intramedullary canal of the femur and then used to align the cutting guide. The attachments used to provide intramedullary alignment are shown in
30 Figures 17 - 19.

The intramedullary attachment comprises a housing 160 which has a triangular projection 161 that mates with the recess 77' within the gap setting device. The housing 160 is maintained in place by means of a screw 164 which engages a threaded hole
35 165 within the recess 77' of the gap checking device. The

housing 160 is shaped to include tracks 166 and 168 in which a slider 170 is positioned. Slider 170 includes an upstanding collar 172 through which the intramedullary rod 174 extends.

5 Two shims 180 with the shape shown in Figure 19 are used in the intramedullary procedure. Each shim includes a support surface 182 which is adapted to contact the distal surface of the femur when the gap checking device is used. The shims are shaped so that they can be supported in the slots 76' of the gap checking device used to make the anterior chamfer cut.

10 The shims 180 are required to make sure that the gap checking device is properly positioned distally since, in the intramedullary procedure, the epicondyles are not located. Without the shims, the gap checking device would contact the femur and the distal cut would not be properly positioned. The shims 180 position the gap checking device so that the distal cut is made at the proper point on the femur.

15 In use, the intramedullary rod 174 may be placed within the intramedullary canal in conventional fashion. The gap checking device is then slid over the intramedullary rod by passing the rod through the collar 172 of slider 170 until the surfaces 182 of shims 180 rest on the patient's femur. The gap checking device can be moved into its desired position because the slider 170 which engages the intramedullary rod is movable within tracks 166 and 168 of rod housing 160.

25 After the gap checking device has been positioned using the shims, pins (not numbered) are driven through the bushings 50' to retain the gap setting device in their proper position with respect to the femur. The bushings 50' shown in Figs. 17-19 include a single neutral hole 56' for the epicondyle pins (as shown in Fig. 7A), although the hole plates of Figs. 14-16 may also be used. The intramedullary rod and its associated assembly are removed from the gap setting device, and the shims 170 are removed from the anterior chamfer slots. Use of the gap setting device and cutting guide are the same as described above.

WHAT IS CLAIMED IS:

1 1. For use in shaping the distal end of a femur
2 preparatory to implantation of a knee prosthesis which includes
3 femoral and tibial components, a gap checking device comprising
4 a curved base adapted to receive the distal end of a
5 patient's femur, the distance between a reference plane and the
6 distal surface of said base being dependent upon the combined
7 thickness of said femoral and tibial components.

1 2. For use in shaping the distal end of a femur
2 preparatory to implantation of a knee prosthesis which includes
3 femoral and tibial components, a gap checking device comprising
4 a curved base adapted to receive the distal end of a
5 patient's femur, and
6 at least one slot in said base through which a cutting
7 device can be passed to form a distal cut in the femur, the
8 distance between said slot and the distal surface of said base
9 being dependent upon the combined thickness of said femoral and
10 tibial components.

1 3. A gap checking device according to claim 2,
2 including means for holding said base on the distal end of the
3 patient's femur.

1 4. A gap checking device according to claim 3,
2 wherein said means for holding engages the epicondyles of the
3 femur.

1 5. A gap checking device according to claim 4,
2 wherein said means for holding engages pins extending into the
3 epicondyles of the femur.

1 6. A gap checking device according to claim 5,
2 wherein said means for holding comprises two spaced arms each
3 attached to said base at one end with the other end adapted to

4 engage said pins, and adjustment means connected to said other
5 ends for shifting the position of the base relative to the femur.

1 7. A gap checking device according to claim 6,
2 wherein said adjustment means comprises a member having at least
3 two holes for selectively engaging the pins.

1 8. A gap checking device according to claim 2,
2 wherein said base includes a plurality of slots through which a
3 cutting device can be passed to shape the femur to conform to
4 said femoral component, and a cutting guide attached to said gap
5 checking device.

1 9. A device for locating the epicondyles of a
2 patient's femur to establish an epicondylar reference axis, said
3 device including:

4 a frame having pair of spaced apart parallel arms
5 and carrying respective inwardly opposed locator means for
6 positioning proximate said epicondyles; and

7 a stylus extending through said horizontal section
8 and slidable with respect thereto, said stylus adapted to engage
9 the trochlear groove of said femur.

1 10. A device for locating the epicondyles of a
2 patient's femur according to claim 9 wherein:

3 said frame includes an adjustment apparatus to
4 vary the horizontal spacing between said locator means.

1 11. A device for locating the epicondyles of a
2 patient's femur according to claim 10, wherein said locator means
3 includes apertures through which pins can be driven into the
4 epicondyles.

1 12. A device for locating the epicondyles of a
2 patient's femur according to claim 11, wherein said stylus

3 includes pivotable elements for locating a plane which is
4 perpendicular to the axis of the epicondyles and passes through
5 the trochlear groove of the femur.

1 13. A method of shaping a patient's femur preparatory
2 to implanting a knee prosthesis having respective femoral and
3 tibial components, said method comprising the steps of:

4 applying a gap checking device to the distal end
5 of the femur, the thickness of the device corresponding in a
6 predetermined way to the thickness of said femoral and tibial
7 components;

8 checking the extension and flexion gaps; and

9 shaping the distal end of said femur for the
10 purpose of receiving the femoral component of said knee
11 prosthesis after the gaps have been checked.

1 14. A method according to claim 13, wherein said gap
2 checking device is referenced to the epicondyles of the knee.

1 15. A method according to claim 13, wherein the distal
2 end of the femur is shaped by passing a cutting device through
3 slots in said gap setting device.

1 16. A method according to claim 15 further including
2 the step of:

3 fastening a cutting guide to said gap checking
4 device; and

5 said shaping step including directing a cutting
6 device through said cutting guide and gap checking device for the
7 purpose of shaping said femur.

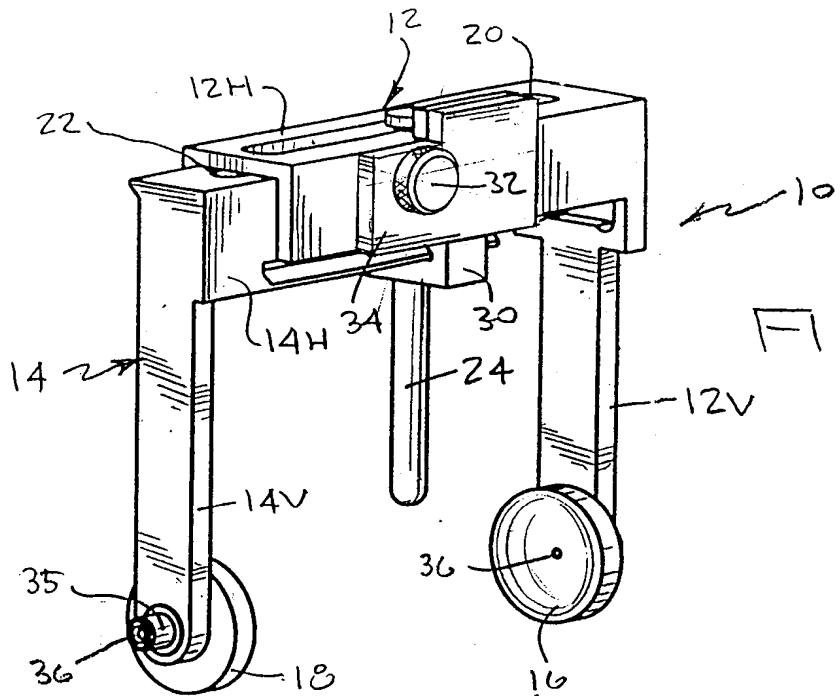

FIG 1

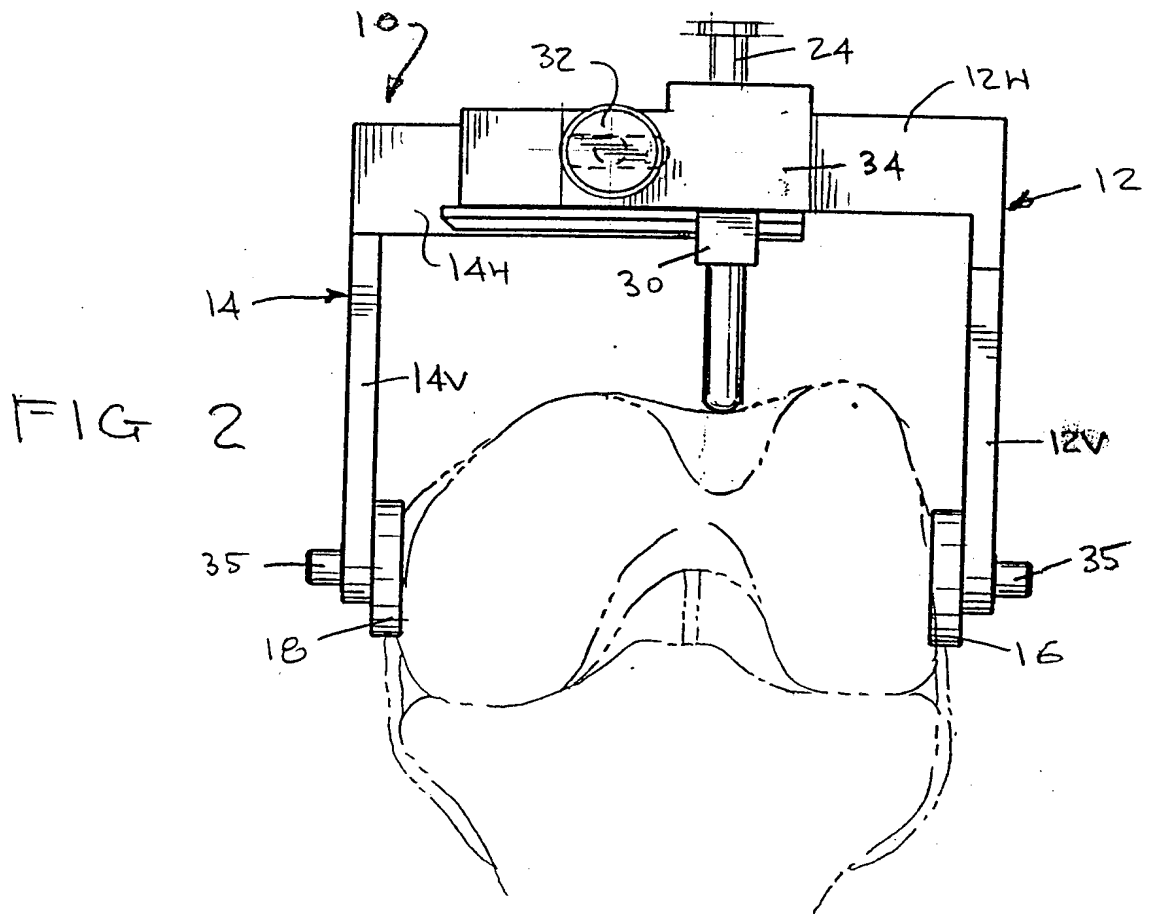
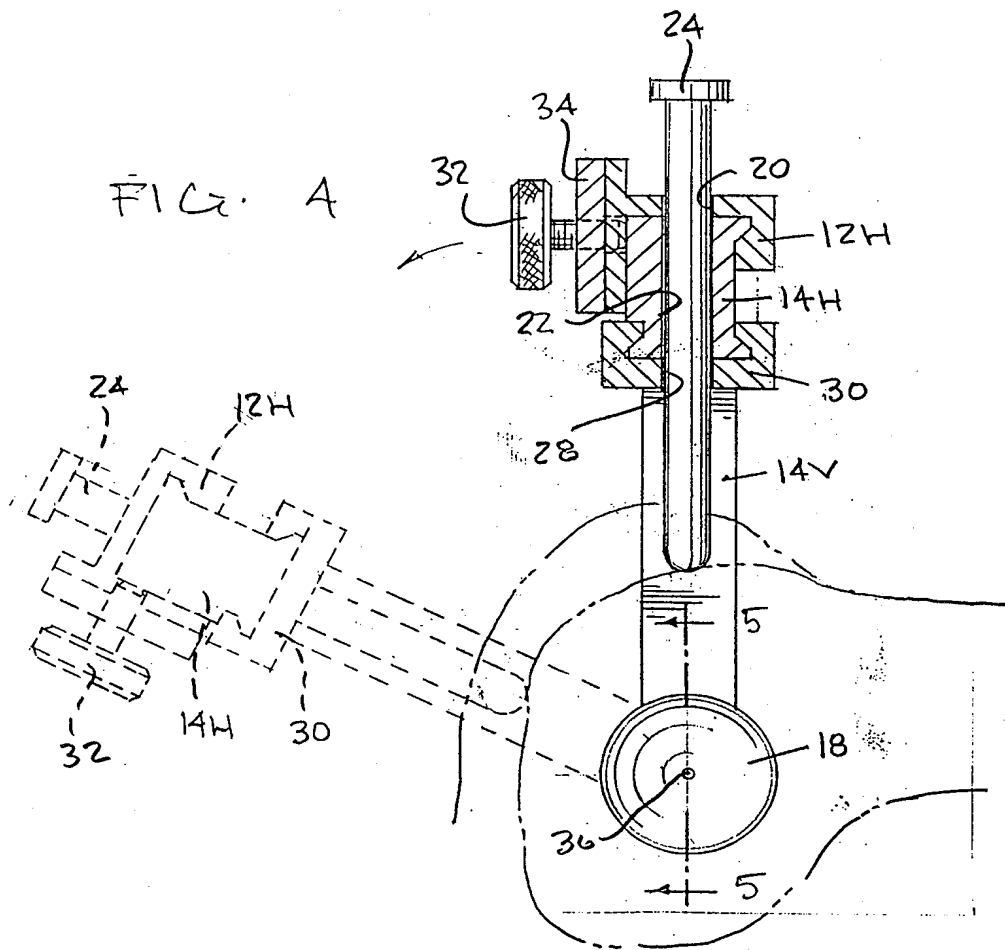
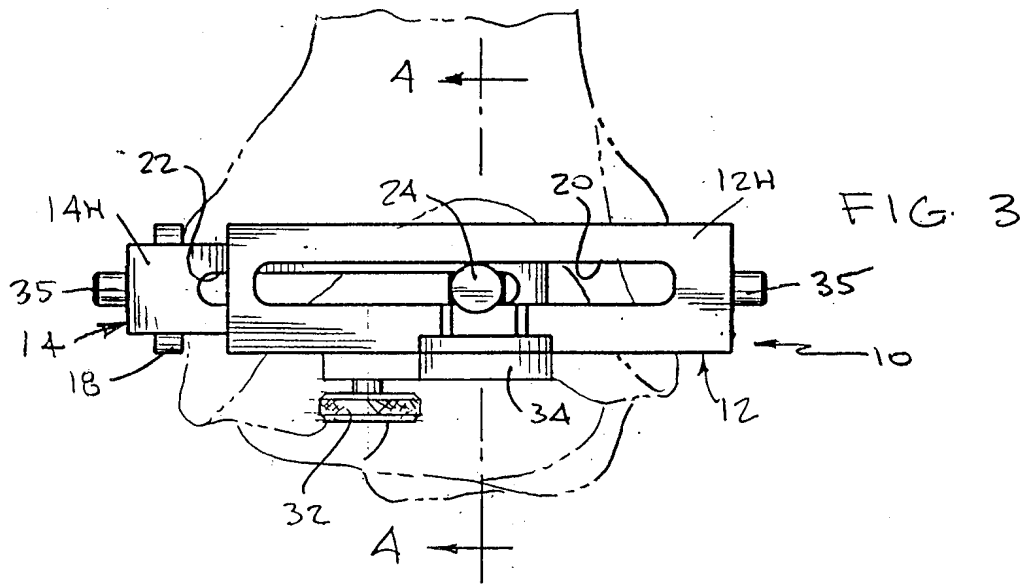

FIG 2



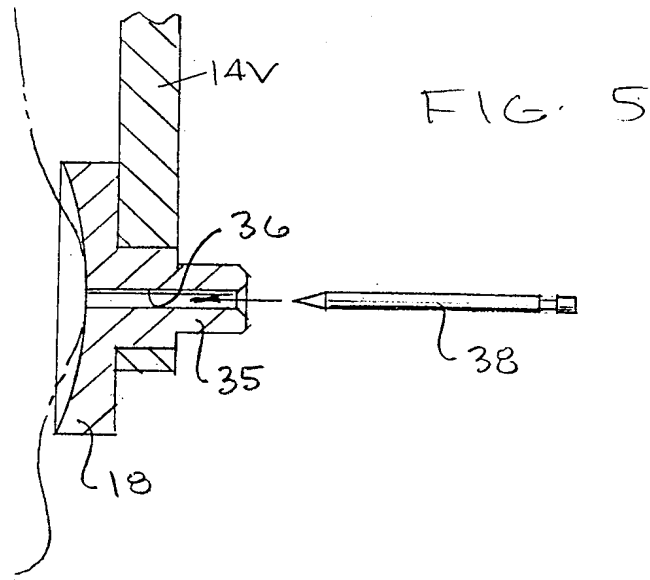

FIG. 8

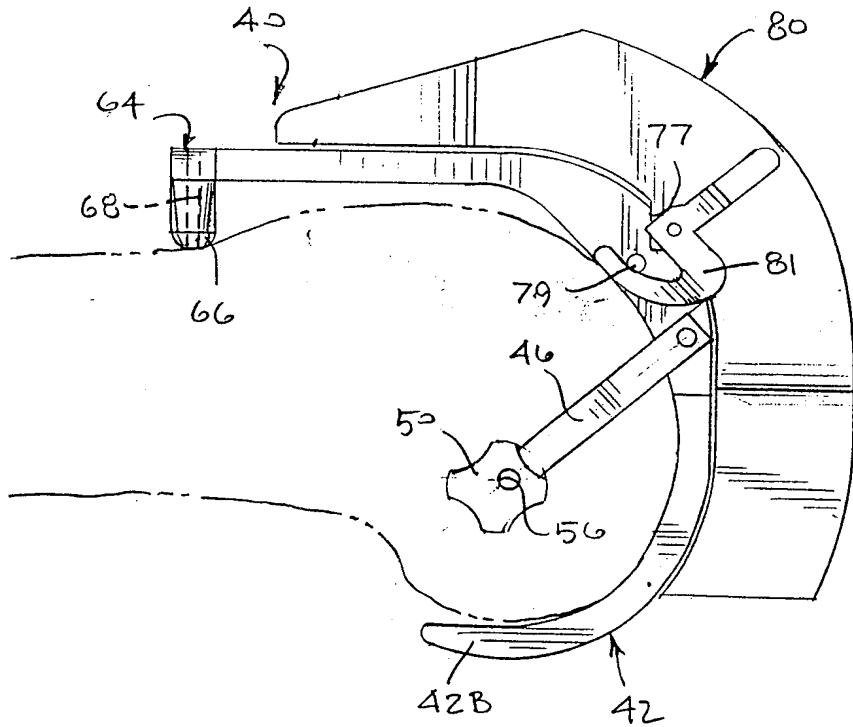

FIG 7A

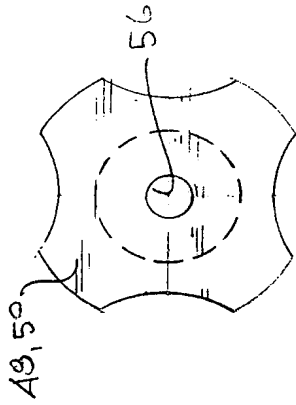

FIG 7B

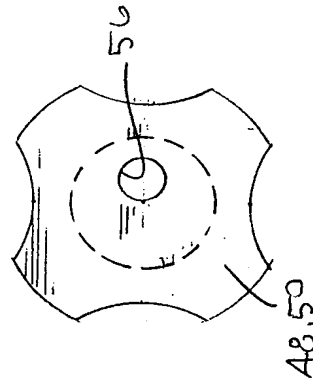

FIG. 6

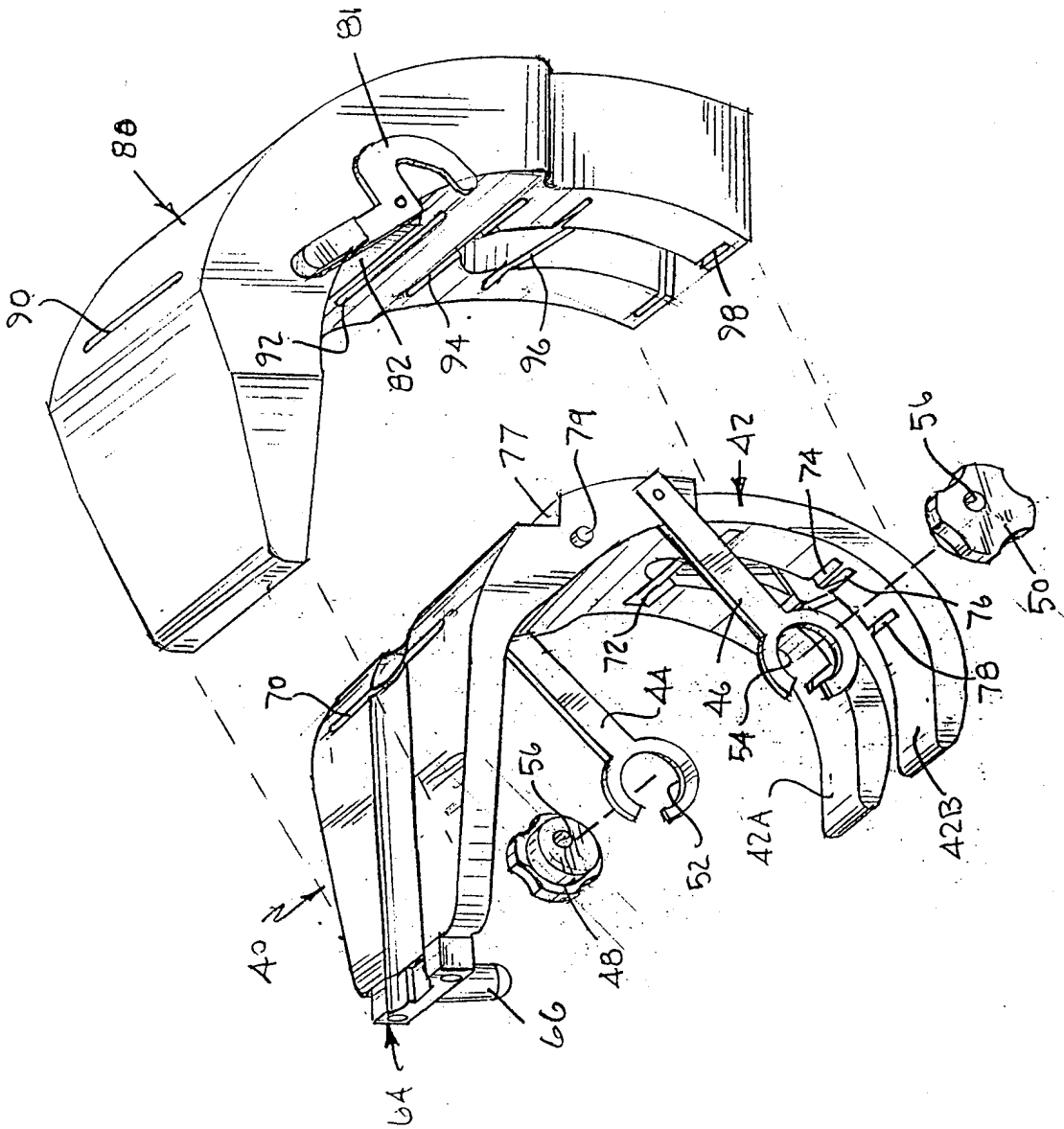

FIG. 9

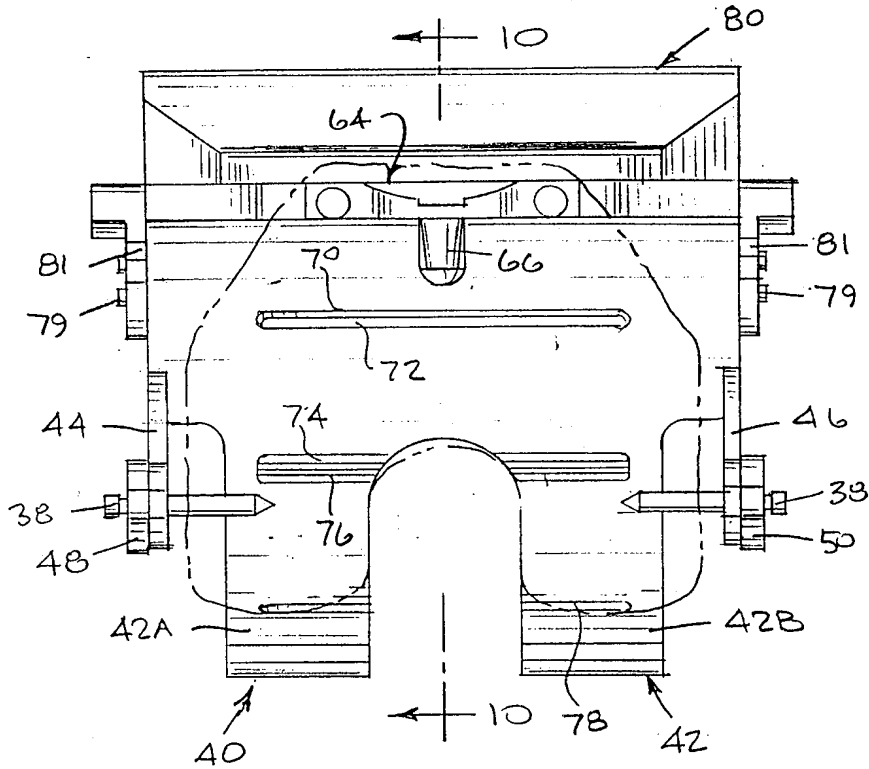

FIG. 10

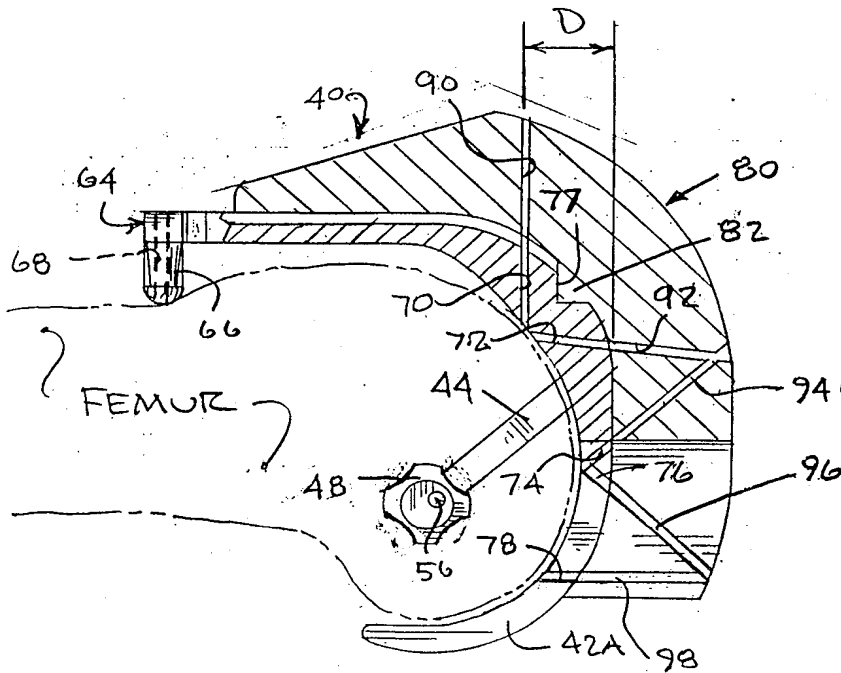

FIG 11

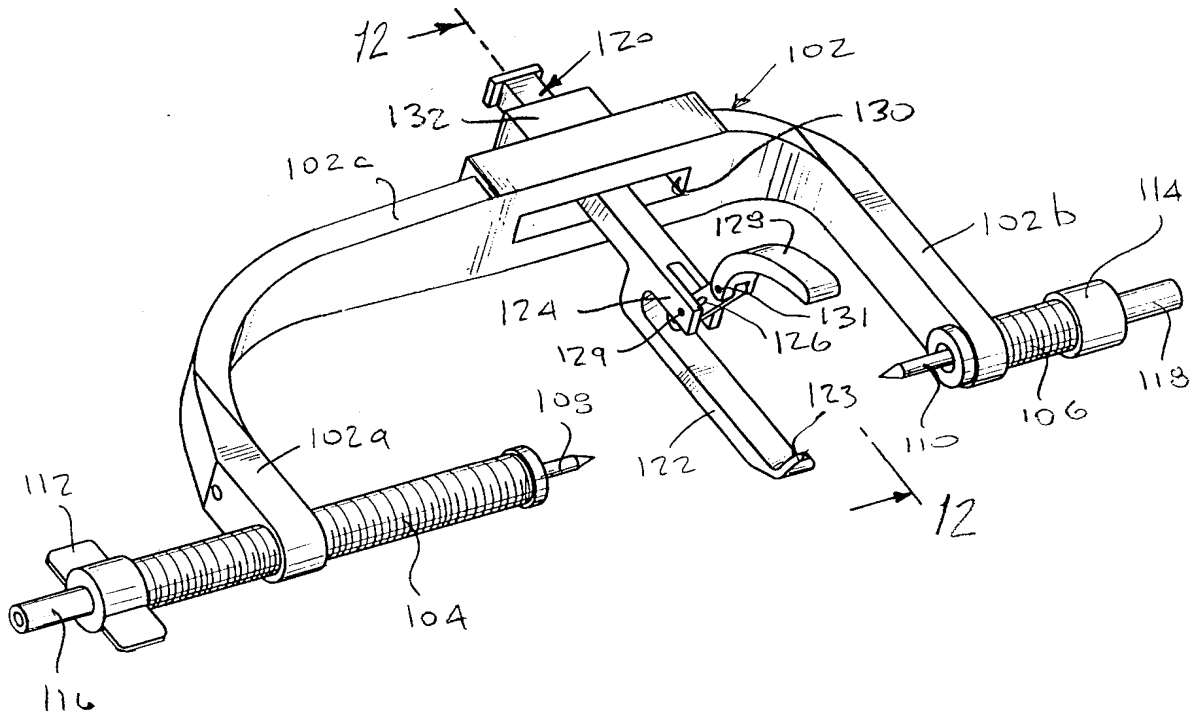

FIG 12

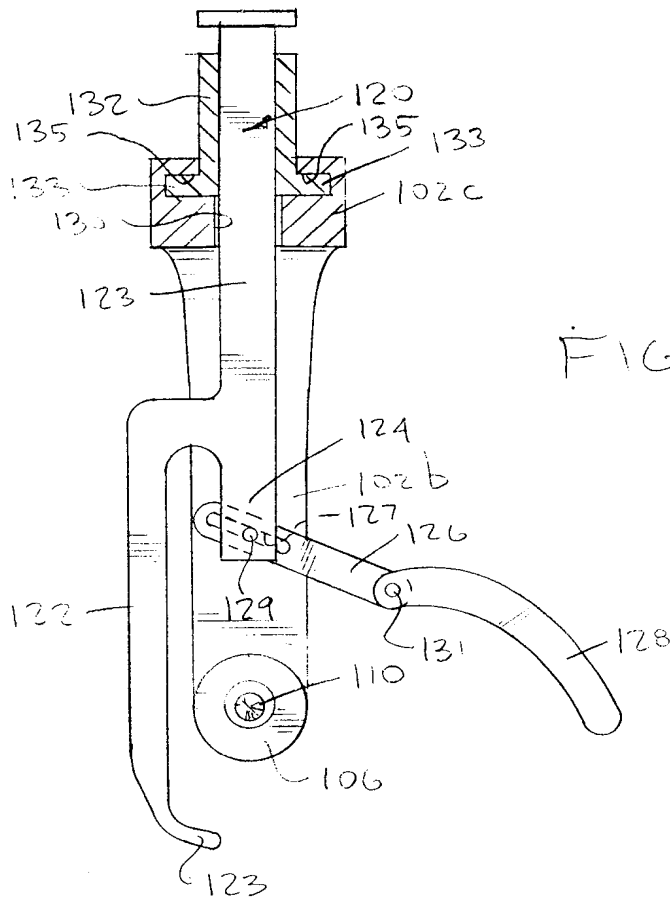

FIG 13

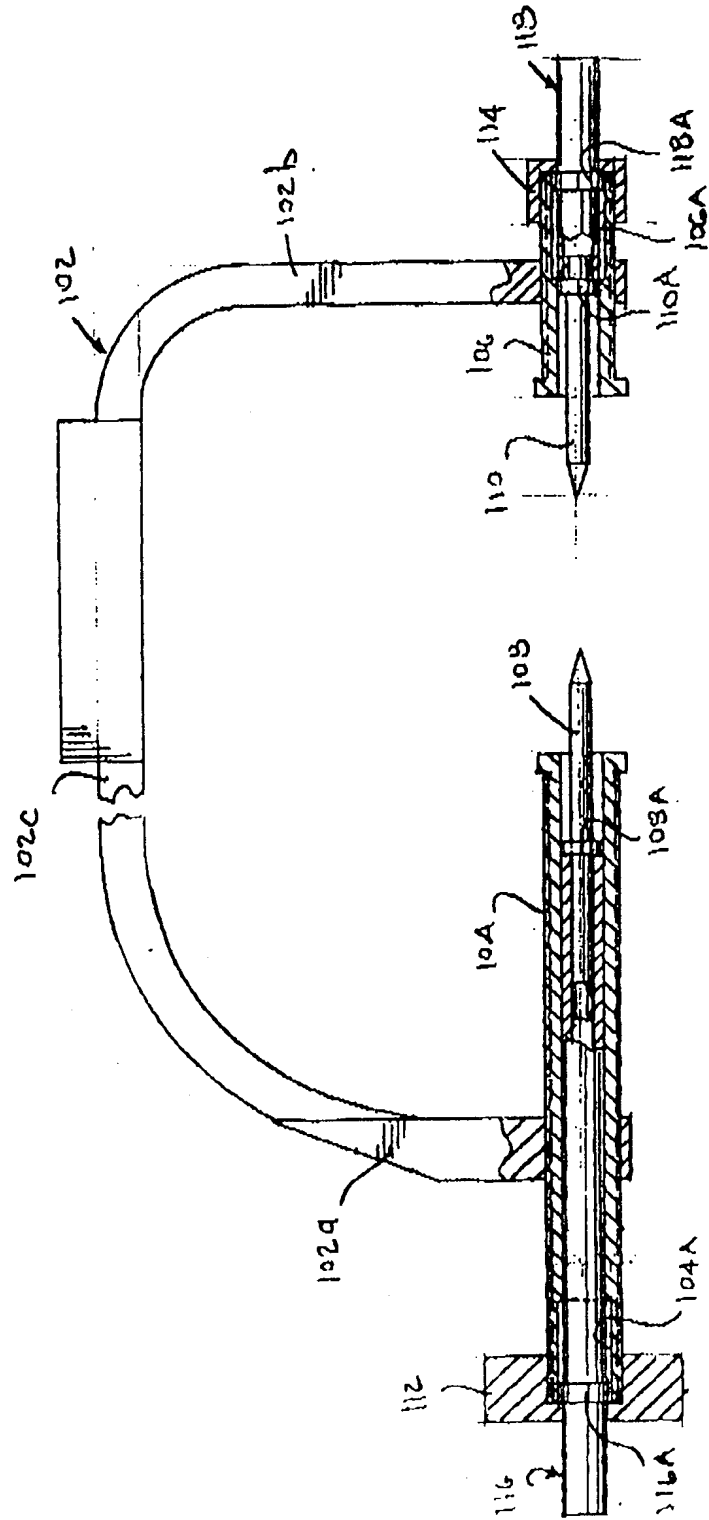

FIG. 14

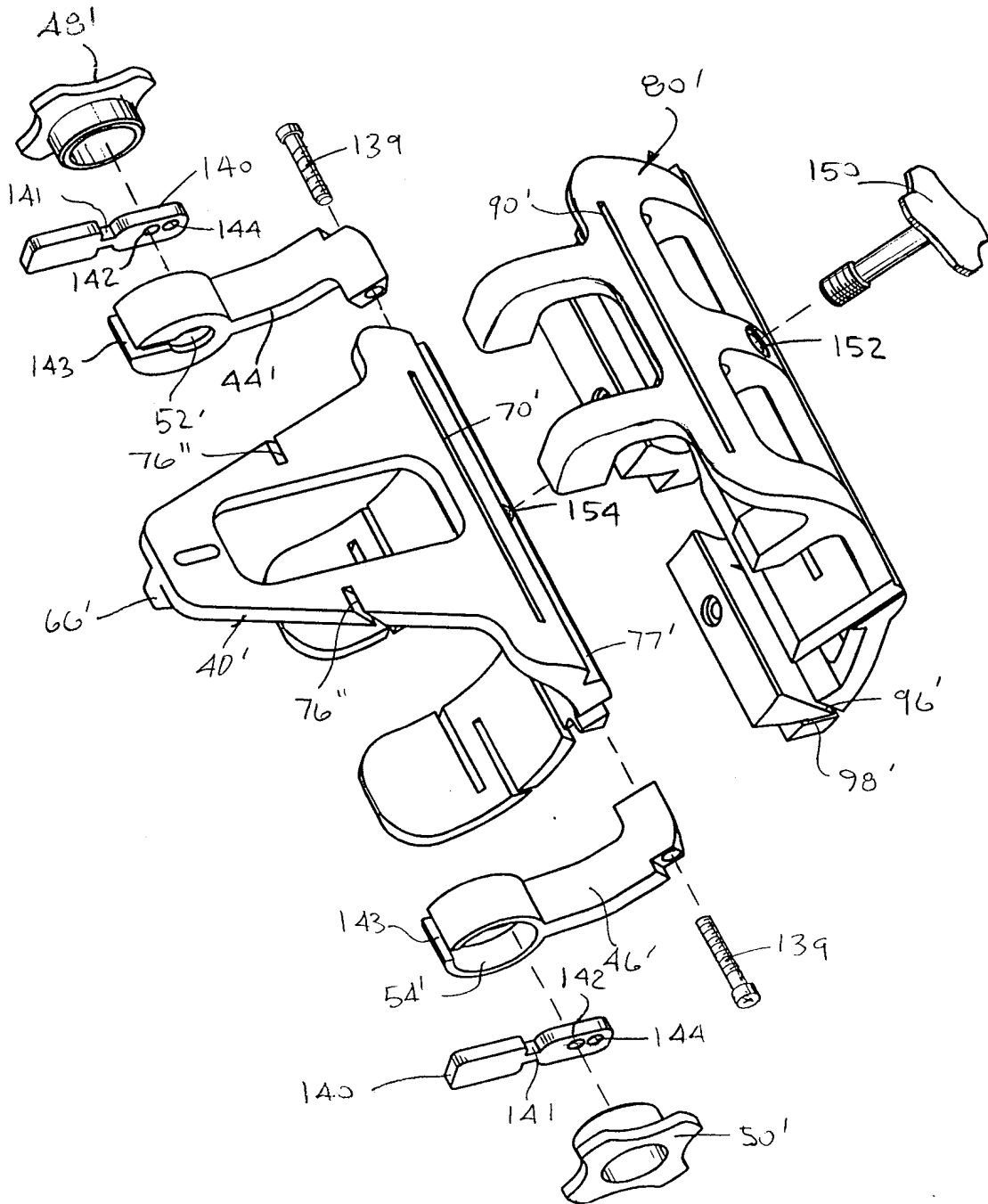

FIG. 15

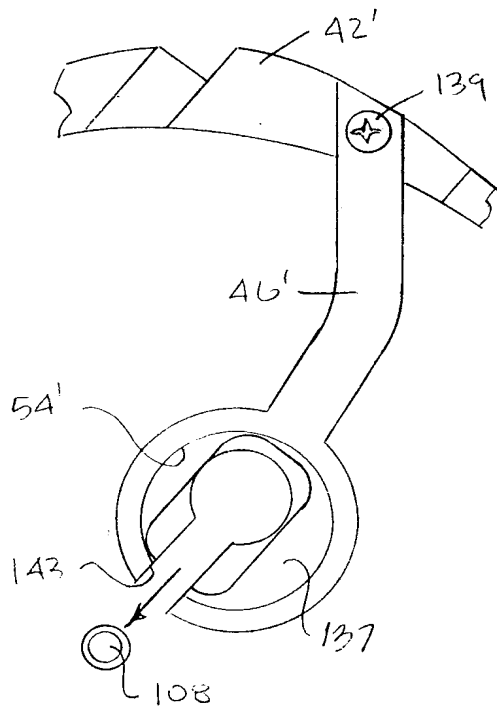

FIG. 15A

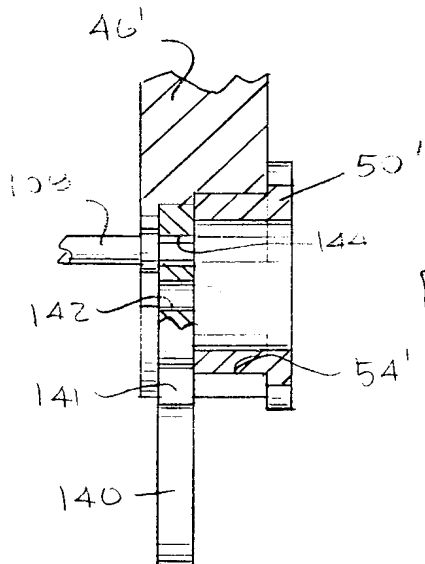
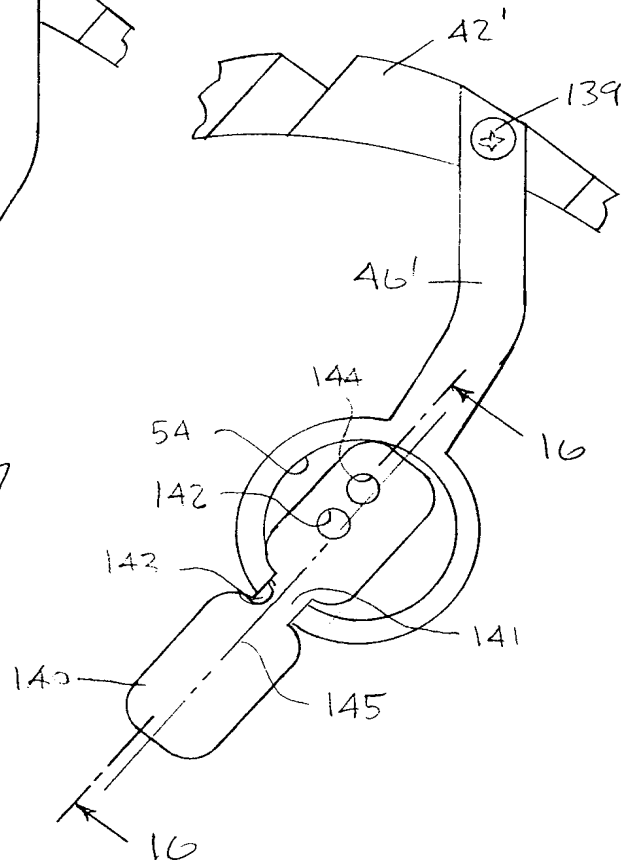

FIG. 16

FIG. 17

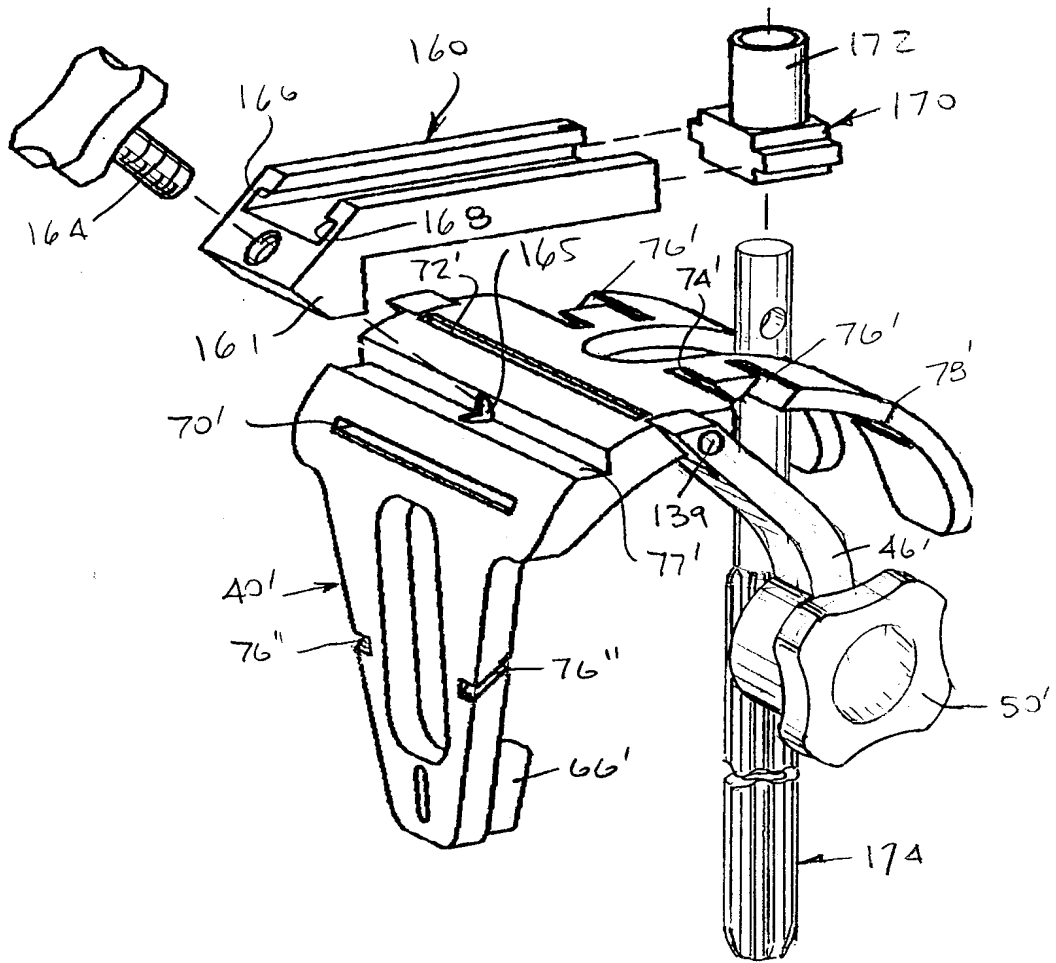

FIG. 18

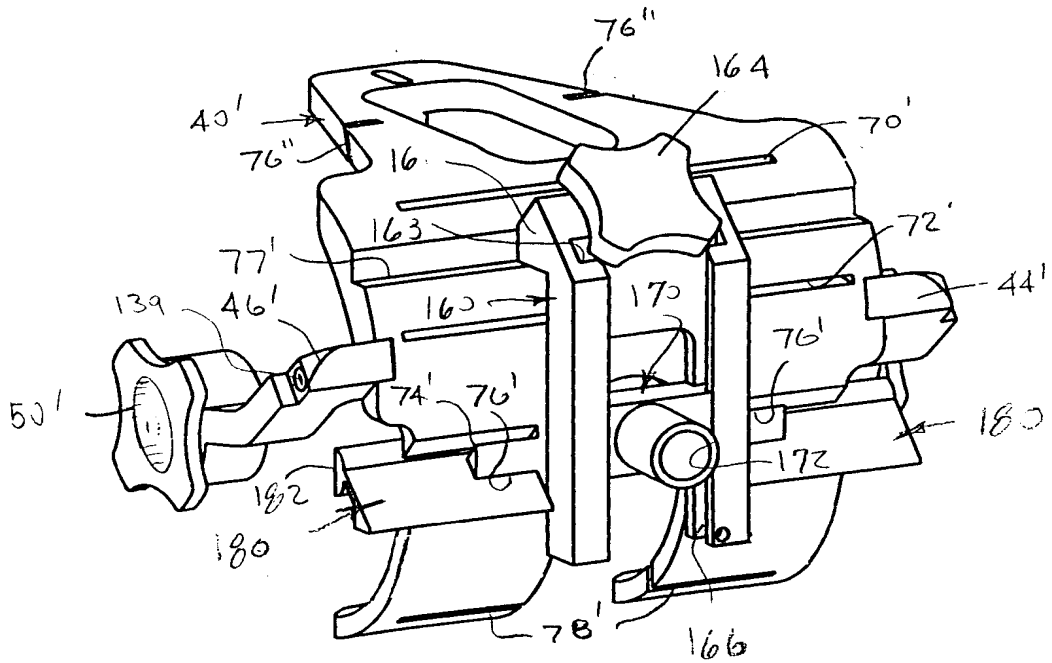

FIG. 19

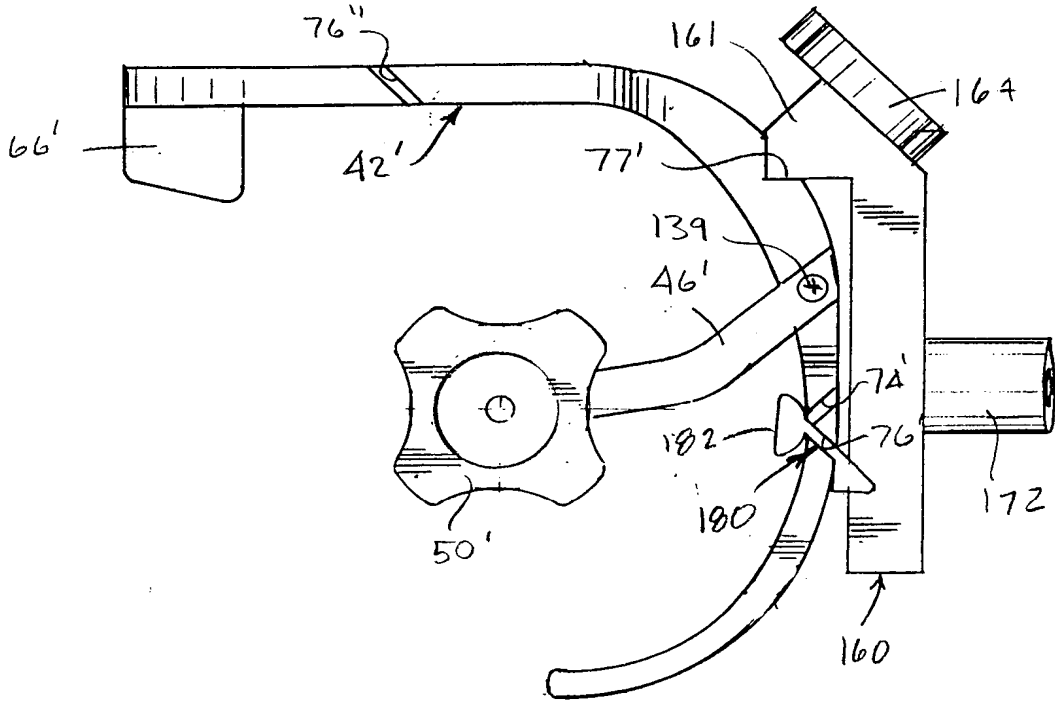
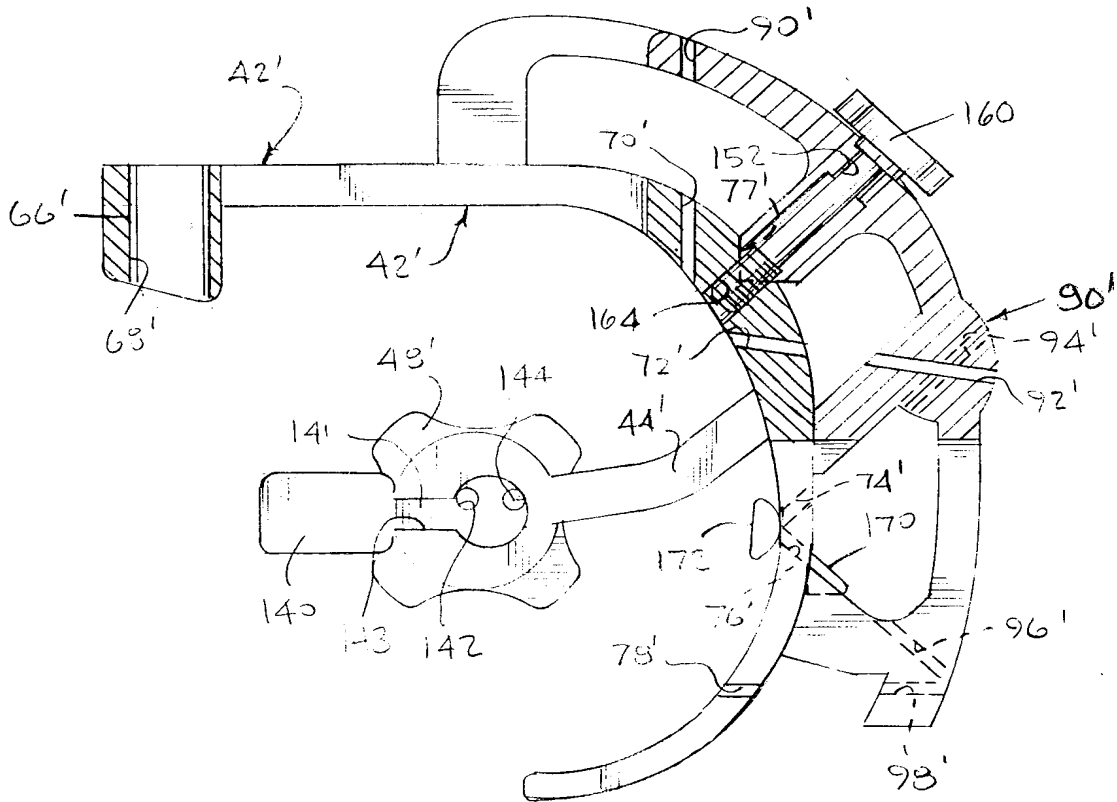

FIG. 20



INTERNATIONAL SEARCH REPORT

International application No.

PCT/US98/01655

A. CLASSIFICATION OF SUBJECT MATTER
 IPC(6) :A61B 17/58
 US CL :606/88
 According to International Patent Classification (IPC) or to both national classification and IPC

B. FIELDS SEARCHED
 Minimum documentation searched (classification system followed by classification symbols)
 U.S. : 433/73; 606/87-89, 102; 623/20

Documentation searched other than minimum documentation to the extent that such documents are included in the fields searched

Electronic data base consulted during the international search (name of data base and, where practicable, search terms used)
 APS
 Search Terms: stylus, condyles, caliper, knee, prosthesis, flexion, extension, gap, thickness, distal, resection, trial

C. DOCUMENTS CONSIDERED TO BE RELEVANT

Category*	Citation of document, with indication, where appropriate, of the relevant passages	Relevant to claim No.
X	US 2,794,253 A (FITZSIMMONS) 04 June 1957, Fig. 1.	9-12
X	US 4,424,035 A (HANSEN) 03 January 1984, Fig. 1.	10-12
X	US 5,098,436 A (FERRANTE et al) 24 March 1992, Figs. 1 and 9.	1
X	US 5,258,032 A (BERTIN) 02 November 1993, Figs. 4 and 6.	1-3
X	US 5,474,559 A (BERTIN et al) 12 December 1995, Figs. 33-37.	1-7
X	US 5,571,197 A (INSALL) 05 November 1996, Fig. 3.	1

Further documents are listed in the continuation of Box C. See patent family annex.

* Special categories of cited documents:	*T* later document published after the international filing date or priority date and not in conflict with the application but cited to understand the principle or theory underlying the invention
A document defining the general state of the art which is not considered to be of particular relevance	*X* document of particular relevance; the claimed invention cannot be considered novel or cannot be considered to involve an inventive step when the document is taken alone
B earlier document published on or after the international filing date	*Y* document of particular relevance; the claimed invention cannot be considered to involve an inventive step when the document is combined with one or more other such documents, such combination being obvious to a person skilled in the art
L document which may throw doubts on priority claim(s) or which is cited to establish the publication date of another citation or other special reason (as specified)	*Z* document member of the same patent family
O document referring to an oral disclosure, use, exhibition or other means	
P document published prior to the international filing date but later than the priority date claimed	

Date of the actual completion of the international search 14 MAY 1998	Date of mailing of the international search report 19 JUN 1998
Name and mailing address of the ISA/US Commissioner of Patents and Trademarks Box PCT Washington, D.C. 20231 Facsimile No. (703) 305-3230	Authorized officer <i>Julian W. Woo</i> JULIAN W. WOO Telephone No. (703) 308-0421

INTERNATIONAL SEARCH REPORT

International application No.
PCT/US98/01655

C (Continuation). DOCUMENTS CONSIDERED TO BE RELEVANT

Category*	Citation of document, with indication, where appropriate, of the relevant passages	Relevant to claim No.
X	SU 1600-749 A (KIEV CLINIC HOSPITAL) 23 October 1990, English Abstract, and Figs. 13 and 14.	9